

The RC Trains Rx65b Receiver / Controller (Accessory wired version)

Thank you for buying the accessory wired version of the **RCT-Rx65b** combined receiver / Electronic Speed Controller (ESC). This starter guide is intended mainly for those unfamiliar with RCT and Deltang radio control equipment, but you might want to keep it handy for future reference. There is more detailed information on the RC Trains and Deltang websites

Getting Started

Wiring

The wiring for incorporating the RCT-Rx65b into a model locomotive is simple - in effect red and black wires to the battery and white wires to the motor. We would, however, recommend including a switch and a fuse (2A-3A) in the leads to the battery. If you are using rechargeable batteries, you could include a charge socket and make the

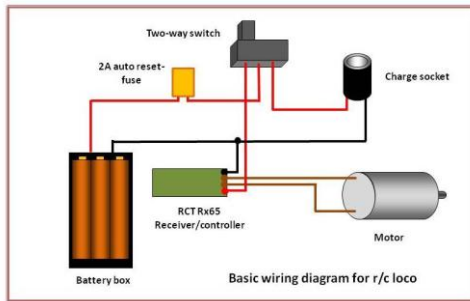

switch two way.

Batteries

3 volt minimum, 18 volt maximum. The receiver senses voltage levels in lithium ion batteries (1S (3.7v) - 3S (11.1v)) and will cut-out when the level of charge drops below safe levels (the LED flashes 5 times). This is to protect the battery from over-discharge. This feature can be disabled if using other types of battery (see *paperclip settings*).

Binding

Before the receiver can be used with a transmitter, the two need to be bound together. The RCT-Rx65b as supplied is designed to work best with the RCT-Tx22 (and Deltang Tx22 or Tx24) but can be used with any DSM2 or DSMX transmitter. To bind the receiver.

1. Make sure the transmitter (Tx) is switched off
2. Turn on the receiver (Rx) and wait for around 20 seconds until the LED on the Rx starts flashing rapidly

3. Turn the Loco Selecta switch on the RCT-Tx22 to the desired position
4. Hold down the bind button on the Tx and then turn on the Tx
5. Release the bind button
6. The LEDs on the Rx and the Tx should flash in unison. When they stop flashing and stay on steadily the Rx and Tx are bound

Note: Sometimes binding is not successful the first time and so the bind process may have to be repeated. Move the Rx and Tx further apart or closer together and try again

Once the Rx and Tx have been bound together, they do not need to be re-bound unless you want to bind the Rx to another Tx or a different Loco Selecta switch position.

Features

Cruise/Failsafe

By default, the RCT-Rx65b is set to *Cruise mode*, which means the loco will continue running at the same speed if it loses the signal from the transmitter (eg when going through a tunnel). If running the loco around a circuit, the Tx can be switched off and the loco will continue to run. The *Cruise* feature can be disabled using *paperclip settings*. This puts the Rx into '*Failsafe mode*' - after five seconds, the loco will come slowly to a halt on the loss of the transmitter signal.

LED status

The LED on the receiver communicates information about the status of the receiver by flashing:

- **Steady on** - The Tx and Rx are bound and communicating satisfactorily
- **1 flash** (2seconds between flashes) = Scanning for Tx signal - no signal or not bound (if never stops).
- **2 flash** = Rx not selected on Loco Selecta.
- **5 flash** = Low Voltage Cut-off/Brownout (ie voltage too low) - check battery and/or motor load.

Output pads

The RCT-Rx65b has 15 output pads which can be programmed for various outputs. The Accessory wired version includes leads connected to the output pads which are likely to be the most useful for those using the receiver with the RCT-Tx22 or Deltang Tx22 or Tx24 transmitters.

Grey lead - Pad 9 - Channel 3 (Direction 1) - Gives 0v output when the switch is moved to the right on the Tx22. Useful for triggering soundcard effects

Purple lead - Pad 10 - Channel 3 (Direction 2) - Gives 0v when the direction switch is moved to the left on the Tx22 - can be used to trigger soundcard effects

Green lead - Pad A - Front light (auto) - Gives 0v output when the loco moves forwards and when connected to an LED (with a suitable resistor connected to the +ve supply from the battery (see RCT website)). Also mirrors the receiver's LED status during bind process etc.

Yellow lead - Pad B - Rear light (auto) - Gives 0v output when the loco moves in reverse and when connected to an LED (with a suitable resistor connected to the +ve supply from the battery (see RCT website)).

Brown lead - Pad C - Channel 5 (Bind button) - Gives 0v output when the bind button is pressed on the Tx22. Useful for triggering soundcard effects such as the horn or whistle.

The default settings for the other output pads are:

- Pad 1 - Front Light -Auto action**, gives 3.5v when on, 0v when off - Can be connected to an LED with a suitable resistor
- Pad 2 - Rear Light -Auto action**, gives 3.5v when on, 0v when off - Can be connected to an LED with a suitable resistor
- Pad 3 - On/Off (Channel 2)**, Momentary action,0v when channel is Low
- Pad 4 - On/Off (Channel 4)**, Momentary action,0v when channel is Low
- Pad 5 - On/Off (Channel 5)**, Latching action, toggles from high to low when bind button is pressed - can be used to trigger soundcard effects such as the horn or whistle
- Pad 6 - On/Off (Channel 3)**, Momentary action,3.5v when channel is Low
- Pad 7 - On/Off (Channel 3)**, Momentary action,3.5v when channel is High
- Pad 8 - Servo (Channel 1)**, Standard servo output - used by some soundcards to sense speed setting
- Pad 11 - On/Off (Channel 3)**, Latching action, toggle when channel is High - can be used to turn on interior lighting etc using direction switch (Direction 1)
- Pad 12 - On/Off (Channel 3)**, Latching action, toggle when channel is Low - can be used to turn on interior lighting etc using direction switch (Direction 2)

Connecting pads to LEDs

LEDs need to have the current limited and so should always be used with a resistor. When using Pads 1 - 12, the output voltage will be 3.5v and so the resistor would normally be around 180 - 470 ohms. When using pads 13-15, the value of the resistor will depend on the supply voltage. In most cases, the current supplied to the LED should not exceed 20mA, but they will often supply plenty of light at 10mA, which also puts less demand on the Receiver. There are plenty of resources on the internet for calculating the value of resistors for LEDs.

Connecting Pads to soundcard triggers

Most soundcards need 0v (ie the equivalent of connection to the negative terminal of the battery) to trigger effects such as the whistle or horn. Pads which supply 0v (eg Pads 9, 10 and 15) can be used as triggers. We would recommend including a 1k resistor in the lead from the pad to the soundcard trigger to protect the receiver from excess current being passed from the soundcard.

Paperclip settings

The RCT-Rx65 can be reprogrammed simply by connecting two output pads together (eg with a paperclip) and then switching on the receiver. The following features can be changed in this way. Apart from factory reset, the settings toggle from one to the other each time they are reprogrammed.

- Perform a '**Hard reset (factory reset)**' (Pads 1 and 2)
- **Change motor control between 'low off' and 'centre off'** (Pads 2 and 3)
- **Enable/disable Low Voltage Cut-off** (eg: when using Nicads, NiHMs or LiFe cells) (Pads 3 and 4)
- **Enable/disable Selecta** (Pads 1 and 3)
- **Enable/disable Cruise Control/Failsafe** (Pads 1 and 4)

NOTE: You will need to remove sections of the plastic heatshrink sleeve to access the pads, which are numbered.

Programming

The RCT-Rx65b can be reprogrammed using a transmitter or Deltang Programma module. See my Blog for more information -

<http://riksrailway.blogspot.com/2015/11/programing-deltang-receivers.html>